

Hard Seated Hand Valves – H7 and H71

³/₁₆-inch [4.8 mm], 6000 and 10,000 psig [414 and 689 barg]

Product Overview

The H7 Series valves are designed for safe, repetitive bubble-tight closure, simple maintenance, and a long, trouble-free life. A free-swiveling ball end stem is incorporated for bubble-tight closure.

A variety of standard end connections and stem packing is available to meet the requirements of NACE. All valves are 100 percent pressure tested. Material traceability of the body is available on request.

Increasing pressures in oil and gas production have led to the development of the H71 valve. Rated to 10,000 psig [689 barg] @ 200°F [93°C], this valve provides long life and bubble-tight shutoff in severe operating conditions.

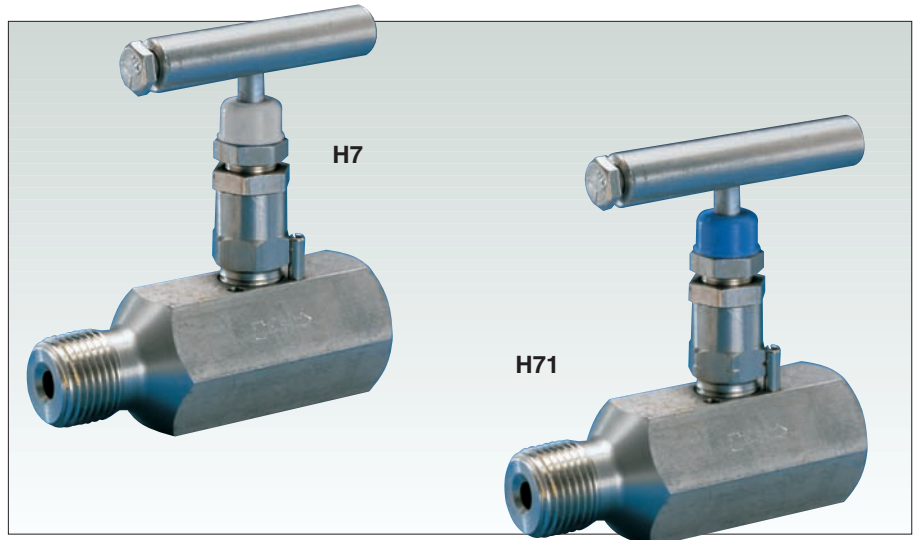

Features and Benefits

- **Ball end stem** eliminates seat galling, provides bubble-tight shutoff and long life. The hardened, non-rotating ball ensures perfect alignment closure.
- **Packing below threads** prevents lubricant washout, thread corrosion, and keeps solids from entering the thread area, which can cause galling. It also prevents process contamination.
- **Adjustable packing** adjusts easily – loosen jam nut, tighten bushing slightly, then retighten jam nut. Decreases packing replacement downtime and increases valve life.
- **Dust cover** prevents lubricant washout and keeps contaminants (dirt, rain, etc.) out of bonnet assembly.
- **Safety back seating** prevents stem blowout or accidental removal while in operation and provides a metal-to-metal secondary stem seal while in the full open position.
- **Panel mount** (optional) affords opportunity to use high quality products in racks or panels.
- **Chrome plating of 316 SS** prevents galling or freezing of stem threads when similar metals mate. CS valves use a 303 SS stem.
- **Rolled threads** provide additional thread strength. The stem, bonnet, and male NPT threads are rolled, not cut.
- **Mirror stem finish** burnished to a 16 RMS finish in the packing area enables smooth stem operation and extends packing life.
- **Body-to-bonnet seal** is metal-to-metal in constant compression, isolating the bonnet threads from process fluid corrosion. Eliminates possible tensile breakage of bonnet, and gives a reliable seal point.
- **Bonnet lock pin** is another safety feature which prevents the accidental separation of the bonnet from the body. However, normal valve maintenance and repair are still easily accomplished.
- **Repairable metal seat** can be resurfaced without removing the valve from the line.

H7 and H71 Specifications⁴

³/₁₆-inch [4.8 mm]: 6000 and 10,000 psig [414 and 689 barg]

Dimensions, inches [mm]

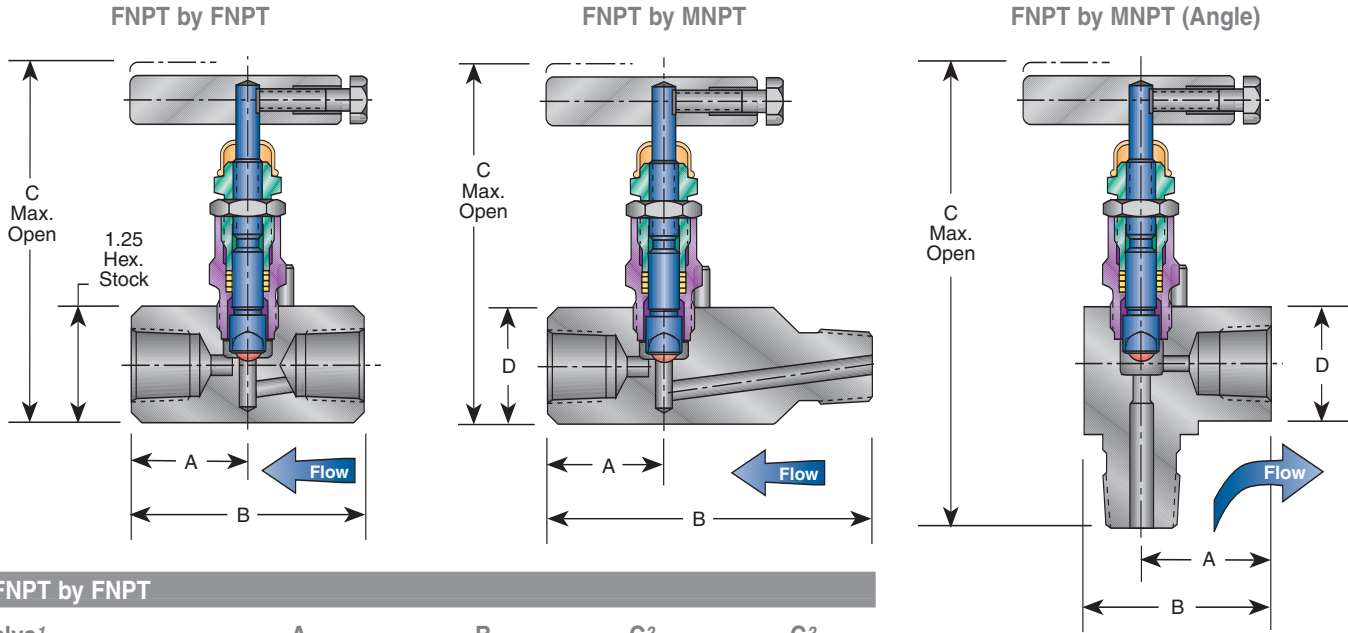

FNPT by FNPT

Valve ¹	A	B	C ² Teflon®	C ² GRAFOIL®
1/4" F x 1/4" F	1.25 [31.8]	2.50 [63.5]	3.92 [99.6]	4.57 [116.1]
1/2" F x 1/2" F ³	1.50 [38.1]	3.00 [76.2]	3.92 [99.6]	4.57 [116.1]

FNPT by MNPT

Valve ¹	A	B	C ² Teflon®	C ² GRAFOIL®	D
1/4" F x 1/2" M	1.25 [31.8]	3.50 [88.9]	3.85 [97.8]	4.50 [114.3]	1.25 [31.8]
1/2" F x 1/2" M	1.25 [31.8]	3.50 [88.9]	3.85 [97.8]	4.50 [114.3]	1.25 [31.8]
3/4" F x 3/4" M	1.50 [38.1]	4.50 [114.3]	4.10 [104.1]	4.75 [120.7]	1.50 [38.1]

FNPT by MNPT (Angle)

Valve ¹	A	B	C ² Teflon®	C ² GRAFOIL®	D
1/2" F x 1/2" M	1.40 [35.6]	2.03 [51.6]	5.00 [127.0]	5.50 [139.7]	1.75 [44.5]

Notes

1. Approximate valve weight: 1.5 lb [0.7 kg].
2. Valve C_v 0.52 maximum.
3. The CS Teflon® packed valve dimension is A-1.25; B-2.50; C-3.92
4. For Hastelloy® and -SG3 call factory for dimensions and weights.

H7 and H71 Specifications⁶

³/₁₆-inch [4.8 mm]: 6000 and 10,000 psig [414 and 689 barg]

Dimensions inches [mm]

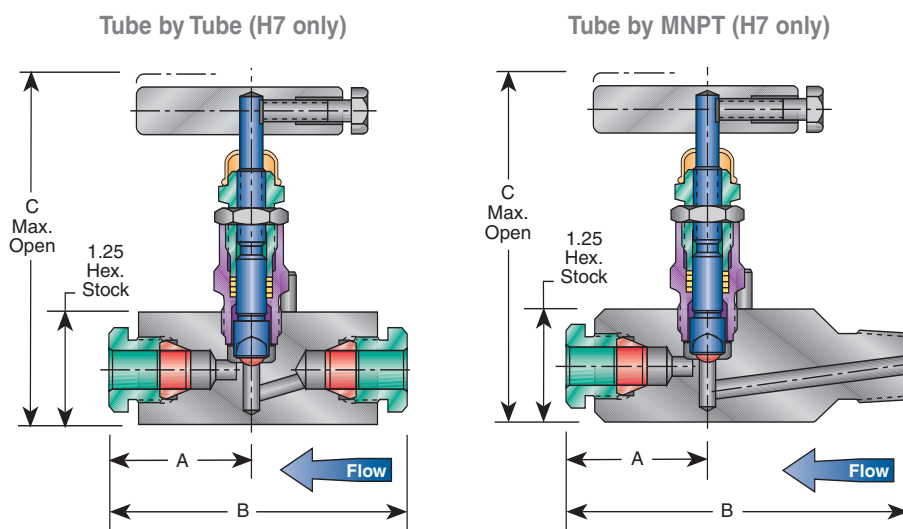

Notes

1. Approximate valve weight: 1.5 lb [0.7 kg].
2. Valve C_v 0.52 maximum.
3. H7 only.
4. SG (Sour Gas) meets the requirements of NACE MR0175/ISO 15156-3 Corrigendum 2 (for Chloride conditions ≤ 50 mg/l [ppm]) and NACE MR0103-2005.
5. CS is zinc cobalt plated to prevent corrosion.
6. SG3 (Sour Gas) meets the requirements of NACE MR0175/ISO 15156-3 Corrigendum 2 (for Chloride conditions > 50 mg/l [ppm]).
7. Elgiloy® is a registered trademark of Elgiloy Specialty Metals.

Tube by Tube (H7 only)

Valve ¹	A	B	C ² Teflon®	C ² GRAFOIL®
1/4" T x 1/4" T	1.68 [42.7]	3.16 [80.3]	3.85 [97.8]	4.50 [114.3]
3/8" T x 3/8" T	1.63 [41.4]	3.75 [95.3]	3.85 [97.8]	4.50 [114.3]
1/2" T x 1/2" T	1.88 [47.8]	3.75 [95.3]	3.85 [97.8]	4.50 [114.3]

Tube by MNPT (H7 only)

Valve ¹	A	B	C ² Teflon®	C ² GRAFOIL®
3/8" T x 1/2" M	1.63 [41.4]	3.88 [98.6]	3.85 [97.8]	4.50 [114.3]
1/2" T x 1/2" M	1.88 [47.8]	4.13 [104.9]	3.85 [97.8]	4.50 [114.3]

Standard Materials

Teflon® Packing (H7 and H71)

Valve	Body and Bonnet ⁵	Stem	Ball
CS	A108	A581 303	17-4 PH
SS	A479-316	A276-316	316 SS
Monel® ³	Monel® R405	Monel® 400	Monel® K500
SG ⁴	A479-316	Monel® 400	Monel® K500
SG3 ⁶	Hastelloy® C-276	Hastelloy® C-276	Elgiloy®

GRAFOIL® Packing (H7 Only)

Valve	Body and Bonnet ⁵	Stem	Ball
CS	A105	A581 303	17-4 PH
SS	A479-316	A276-316	316 SS
SG ⁴	A479-316	Monel® 400	Monel® K500
SG3 ⁶	Hastelloy® C-276	Hastelloy® C-276	Elgiloy®

H7 and H71 Specifications

³/₁₆-inch [4.8 mm] Orifice: 6000 and 10,000 psig [414 and 689 barg]

Pressure vs. Temperature – H7

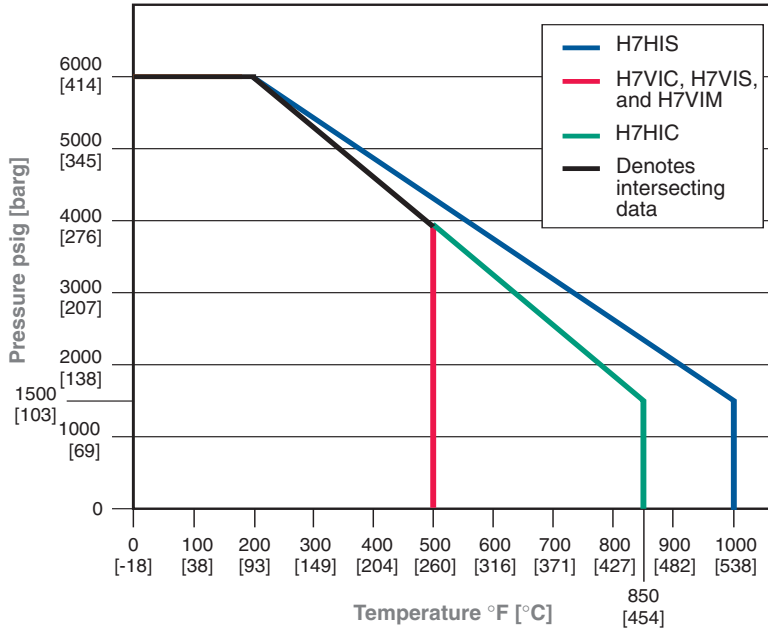

Pressure and Temperature Ratings

Valve	Teflon® Packed Bonnet	
CS	6000 psig @ 200°F	[414 barg @ 93°C]
	1500 psig @ 850°F	[103 barg @ 454°C]
SS	6000 psig @ 200°F	[414 barg @ 93°C]
	1500 psig @ 1000°F	[103 barg @ 538°C]
Monel®	6000 psig @ 200°F	[414 barg @ 93°C]
	1500 psig @ 850°F	[103 barg @ 454°C]
Hastelloy®	6000 psig @ 200°F	[414 barg @ 93°C]
	1500 psig @ 850°F	[103 barg @ 454°C]

Valve GRAFOIL® Packed Bonnet and Low Emissions Graphite Packed Bonnet

CS	6000 psig @ 200°F	[414 barg @ 93°C]
	1500 psig @ 850°F	[103 barg @ 454°C]
SS	6000 psig @ 200°F	[414 barg @ 93°C]
	1500 psig @ 1000°F	[103 barg @ 538°C]
Hastelloy®	6000 psig @ 200°F	[414 barg @ 93°C]
	1500 psig @ 850°F	[103 barg @ 454°C]

Pressure vs. Temperature – H71

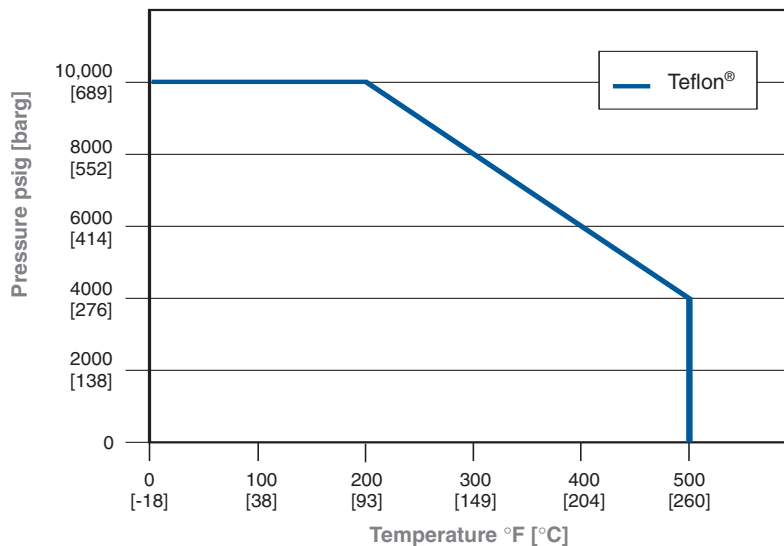

Pressure and Temperature Ratings

Valve	Teflon® Packed Bonnet	
CS, SS	10,000 psig @ 200°F	[689 barg @ 93°C]
SS, SG3	4000 psig @ 500°F	[276 barg @ 260°C]

H7 and H71 Options

³/₁₆-inch [4.8 mm] Orifice: 6000 and 10,000 psig [414 barg]

AGCO Tube¹

Integral Tube Fitting Design (H7 only)

- Proven design performance
- No tube twist on makeup
- Low torque assembly
- Male nut
 - Silver-plated to prevent galling
 - Threads are rolled for additional strength
 - Gives superior tubing support for vibration resistance
- Bubble-tight seal on make and remakes
- Fitting will hold to the burst of the tubing
- Makeup is industry standard 1¼ turns from finger tight.
- Remake is ¼ turn from finger tight which brings you back to original position, then snug slightly to respring the ferrule(s) into a sealing position.

Available with single or dual ferrule design:

Single Ferrule Design

Option is ‘-() AT’

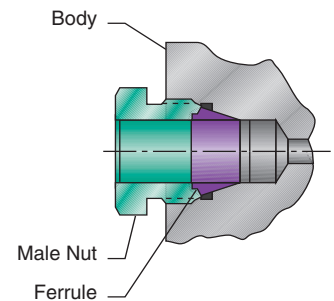

Dual Ferrule Design

Option is ‘-() ATD’

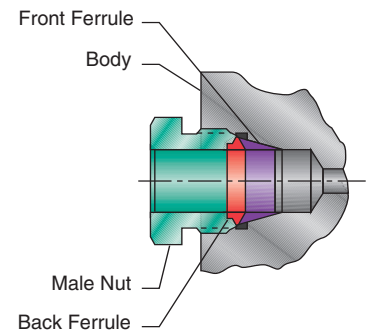

Note

1. AGCO Tube option meets the requirements of NACE.

Bonnet Lock (BL)¹

The Anderson Greenwood Bonnet Lock prevents accidental loosening of the bonnet-to-body seal. A high-strength, short bonnet pin aligns a hex collar over the bonnet. A standard panel nut locks the collar against the valve. Tests indicate the minimum torque required to break the collar loose is greater than the torque required to twist off handle. Available with GRAFOIL[®] packed bonnets only.

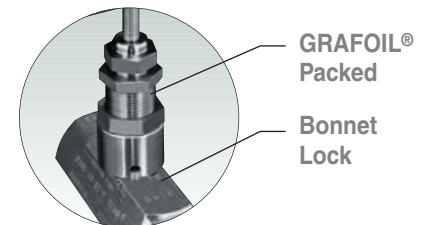

Note

1. Patent protected.

H7 Specifications

³/₁₆-inch [4.8 mm] Orifice: 6000 psig [414 barg]

Ordering Information

H7 V I S - 44Q - SG

Packing

- V - Teflon®
- H - GRAFOIL®
- E - Low Emissions Graphite

Seat

- I - Integral

Material

- C - CS
- S - 316 SS
- M - Monel®
- J - Hastelloy®

Connections (Inlet/Outlet)

- 2 - 1/4-inch FNPT x 1/4-inch FNPT
- 24 - 1/2-inch MNPT x 1/4-inch FNPT
- 4Q - 1/2-inch FNPT x 1/2-inch FNPT
- 44Q - 1/2-inch MNPT x 1/2-inch FNPT
- 46Q - 3/4-inch MNPT x 1/2-inch FNPT
- 44QA - 1/2-inch MNPT x 1/2-inch FNPT Angle
- 4AT - 1/2-inch Tube x 1/2-inch Tube
- 66Q - 3/4-inch MNPT x 3/4-inch FNPT

Option/Descriptions

- AL - Arctic Lubricant (low temperature service -70°F) - not available for CS valves
- BL - Bonnet Lock (patent protected) (page 21)
- PHB - Phenolic Round Black Handle
- PM - Panel Mount (GRAFOIL® bonnet only)
- C - Male Plain End
- SG - (Sour Gas) meets the requirements of NACE MR0175/ISO 15156-3 Corrigendum 2 (for Chloride conditions ≤ 50 mg/l [ppm]) and NACE MR0103-2005 (316 SS only)
- SG3 - (Sour Gas) meets the requirements of NACE MR0175/ISO 15156-3 Corrigendum 2 (for Chloride conditions > 50 mg/l [ppm])
- SP - Special Requirements - please specify

H71 Specifications

³/₁₆-inch [4.8 mm] Orifice: 10,000 psig [689 barg]

Ordering Information

	H71	V	I	S	- 44Q	- SG
Packing						
	V - Teflon®					
Seat						
	I - Integral					
Material						
	C - CS					
	S - 316 SS					
	J - Hastelloy®					
Connections (Inlet/Outlet)						
	2 - 1/4-inch FNPT x 1/4-inch FNPT					
	24 - 1/2-inch MNPT x 1/4-inch FNPT					
	4Q - 1/2-inch FNPT x 1/2-inch FNPT					
	44Q - 1/2-inch MNPT x 1/2-inch FNPT					
	46Q - 3/4-inch MNPT x 1/2-inch FNPT					
	44QA - 1/2-inch MNPT x 1/2-inch FNPT Angle					
Option/Descriptions						
	AL - Arctic Lubricant (low temperature service -70°F) - not available for CS valves					
	BL - Bonnet Lock (patent protected) (page 21)					
	PHB - Phenolic Round Black Handle					
	SG - (Sour Gas) meets the requirements of NACE MR0175/ISO 15156-3 Corrigendum 2 (for Chloride conditions ≤ 50 mg/l [ppm]) and NACE MR0103-2005 (316 SS only)					
	SG3 - (Sour Gas) meets the requirements of NACE MR0175/ISO 15156-3 Corrigendum 2 (for Chloride conditions > 50 mg/l [ppm])					
	SP - Special Requirements - please specify					

Hard Seated Valves – H7 ASME B31.1 or B31.3

³/₁₆-inch [4.8 mm] ASME B31.1 or B31.3 – Meets MSS-SP-105

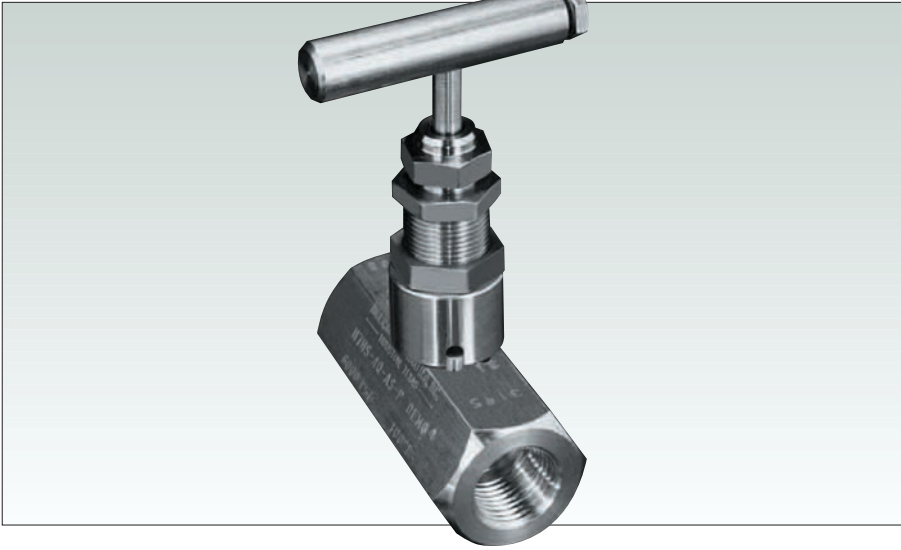

Globe pattern instrument hand valve used in severe service isolation, drain and test applications.

Features and Benefits

- **Stem packing** is GRAFOIL® standard for high-temperature service.
- **Free-swiveling SS ball stem** prevents seating surface damage and ensures perfect alignment cycle after cycle. The differential hardness between the ball and seat assures bubble-tight shutoff.
- **One-piece handle assembly** prevents loss due to vibration or maintenance. If handle is removed, locking bolt remains with handle.
- **Rolled stem threads** prevent galling and extend valve life. Stem is polished to a mirror finish to minimize packing wear.
- **Back Seat design** provides secondary stem seal and prevents accidental stem blowout under pressure.
- **Full pressure and temperature range** up to ASME Class 2500.
- **Bonnet lock (patented)** prevents accidental loosening of the bonnet-to-body seal. A high-strength short bonnet pin aligns a hex collar over the bonnet. A standard panel nut then locks the collar against the valve body. The nut allows all instrument valves to be panel-mounted without any additional parts. Tests indicate that the minimum torque required to break the collar loose is greater than the torque required to twist off the valve handle.
- **Bonnet-to-body, metal-to-metal seal point** places the seal in constant compression below the bonnet threads. This prevents bonnet thread corrosion, eliminates possible tensile breakage of the bonnet, and provides a reliable seal point.
- **Repairable metal seat** can be resurfaced without removing the valve from the line.
- **Code materials of construction** are designed to meet requirements of ASME B31.1 or ASME B31.3.
- **Optional end connections**
 - Pipe Socket Weld
 - AGCO Tube
 - Tube Socket Weld
 - Tube Stub
 - FNPT

Hard Seated Valves – H7 ASME B31.1 or B31.3

³/₁₆-inch [4.8 mm] ASME B31.1 or B31.3 – Meets MSS-SP-105

ASME B31.1 or B31.3

Valve design criteria is described in Section 107. Important considerations from this section are as follows:

1. Valves require specific pressure and temperature ratings such as those found in ASME B16.34.
2. Material requirements must conform to listed ASTM specifications.
3. As a minimum, the valve body should be marked or tagged in accordance with specification MSS-SP-25.
4. Valve design may include screwed, union, or OS&Y bonnets.

The requirements for instrument, control, and sampling systems are found in Section 122. Instrument piping, as defined by this section, includes that piping from the instrument root valve (or first valve off the main piping line) up to but not including the instrument, transmitter, or any other measuring and sensing device.

The instrument valve or manifold must be designed to withstand full system design pressure at the design temperature or the corresponding saturation temperature if the service is steam. Even though the instrument will never be subjected to the

system temperature, manifold design requires this protection in the event that the root valve should fail under operating conditions. If blowdown valves are used between the root valve and the manifold, then the manifold design temperature rating need only be 100°F [38°C]. However, in such cases, the pressure rating must be the lesser of 1.5 times the mainline design pressure or the rating of the blowdown valve. The utilization of commercial grade manifolds (without the manufacturer's certification to ASME B31.1 or B31.3 or if stamped WOG) which meet only the pressure ratings are prohibited unless all other code requirements have been met (such as Table 126.1 in ASME B31.1 or B31.3 for materials, compliance to testing requirements, etc).

The final section of the Code, Section I, 137, specifies the criteria for testing. All instrument manifold valves are required to be hydrostatically tested by the manufacturer to certify compliance with the Code. Hydrostatic testing is performed, as a minimum, in accordance with MSS-SP-61. This testing includes the body cavity hydrostatic test at 1.5 times the design pressure rating and seat leakage test(s) at 1.1 times the maximum pressure rating.

Pressure and Temperature Ratings

Body Material	Pressure and Temperature Ratings			
SS, A479-316	6000 psig @	100°F	[414 barg @	38°C]
	2915 psig @	1000°F	[201 barg @	538°C]
CS, A105	6170 psig @	100°F	[426 barg @	38°C]
	3430 psig @	800°F	[237 barg @	426°C]
Hastelloy®	6170 psig @	100°F	[426 barg @	38°C]
	3430 psig @	800°F	[237 barg @	426°C]

Notes

1. All B31.1 or B31.3 products are ASME Class 2500.
2. Approximate valve weight: 1.3 lb [0.6 kg].
Orifice Size 0.187-inch [4.8 mm].
Valve C_v 0.52 maximum.

