



76-100 Series

Stainless Steel Ball Valve

Threaded, 1/4" to 1" 2000 psig WOG, 1-1/4" to 2" 1500 psig WOG, 2-1/2" to 3" 1000 psig WOG. (See referenced P/T chart)
 Cold Non-Shock. 150 psig Saturated Steam, Vacuum Service to 29 inches Hg.
 Federal Specification: WW-V-35C, Type: II, Composition: SS, Style: 3.
 MSS SP-110; Ball Valves Threaded, Socket-Welding, Solder Joint, Grooved and Flared Ends.

FEATURES

- Investment cast components
- RPTFE seats and stuffing box ring
- Mounting pad for easy actuator mounting
- Blow-out-proof stem design
- Adjustable packing gland
- Meets NACE MR-01-75
- SS lever and nut
- (-24) 1/4" to 2" Certified to API 607, 4th Edition, Class 600 burn

STANDARD MATERIAL LIST

1. Lever and grip	304 SS w/vinyl	7. Gland nut	A276-316
2. Stem packing	RPTFE	8. Stem	A276-316
3. Stem bearing	RPTFE	9. Lever nut	18-8 SS
4. Ball	A276-316	10. Body seal	PTFE
5. Seat (2)	RPTFE	11. Body	A351-CF8M
6. Retainer	A351-CF8M		

OPTIONS AVAILABLE:

SUFFIX	OPTION	SIZES
-02-	Stem Grounded	1/4" to 3"
-03-	1-1/4" CS Stem Extension	1/4" to 3"
-04-	2-1/4" CS Stem Extension	1/4" to 3"
-07-	Steel Tee Handle	1/4" to 2"
-08-	90° Reversed Stem	1/4" to 3"
-14-	Side Vented Ball (Uni-Directional)	1/4" to 2"
-15-	Wheel Handle, Steel	1/4" to 2"
-16-	Chain Lever - Vertical	3/4" to 2"
-19-	Lock Plate	1/4" to 2"
-21-	UHMWPE Trim (Non-PTFE)	1/4" to 3"
-24-	Graphite Packing	1/4" to 3"
-27-	SS Latch-Lock Lever & Nut	1/4" to 3"
-30-	Cam-Lock and Grounded	1/4" to 2"
-32-	SS Tee Handle & Nut	1/4" to 2"
-35-	VTFE Trim	1/4" to 3"
-39-	SS Hi-Rise Locking Wheel Handle, SS Nut	1/4" to 2"
-40-	Cyl-Loc and Grounded	1/4" to 2"
-44-	Seal Welded	1/4" to 2"
-45-	Less Lever & Nut	1/4" to 3"
-46-	Latch Lock Lever - Lock in Closed Position Only	1/4" to 3"
-47-	SS Latch Lock Oval Handle	1/4" to 1"
-48-	SS Oval Handle (No Latch) & Nut	1/4" to 2"
-49-	Assembled Dry	1/4" to 3"
-50-	2-1/4" CS Locking Stem Extension	1/4" to 3"
-57-	Oxygen Cleaned	1/4" to 3"
-58-	Chain Lever - Horizontal	3/4" to 2"
-60-	Static Grounded Ball & Stem	1/4" to 3"
-64-	250# Steam Trim	1/4" to 3"
-P01-	BSPP (Parallel) Thread Connection	1/4" to 3"
-T01-	BSPT (Tapered) Thread Connection	1/4" to 3"

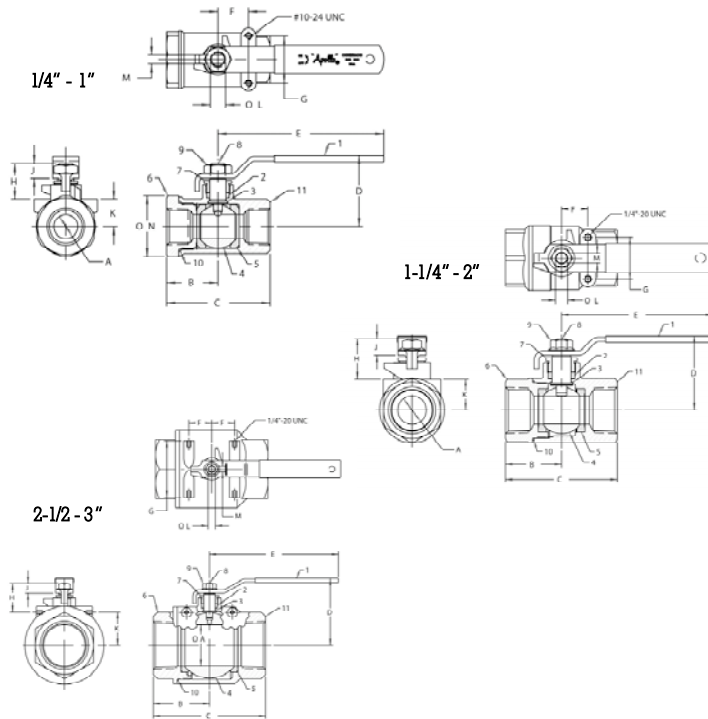

STAINLESS STEEL BALL VALVE

NUMBER	SIZE	A	B	C	D	E	F	G	H	J	K	L	M	N	WT.
76-101-01A	1/4"	.37	1.02	2.05	1.71	3.85	.50	1.12	.88	.34	.53	.375	.234	1.16	.58
76-102-01A	3/8"	.37	1.02	2.05	1.71	3.85	.50	1.12	.88	.34	.53	.375	.234	1.16	.55
76-103-01A	1/2"	.50	1.12	2.23	1.79	3.85	.50	1.12	.90	.34	.59	.375	.234	1.38	.63
76-104-01A	3/4"	.75	1.47	2.96	2.03	4.75	.87	1.37	1.02	.42	.78	.437	.256	1.75	1.30
76-105-01A	1"	1.00	1.67	3.34	2.16	4.75	.87	1.37	1.02	.42	.91	.437	.256	1.94	1.60
76-106-01	1-1/4"	1.00	2.00	4.00	2.68	5.40	.94	1.50	1.50	.60	1.12	.625	.377	-	3.10
76-107-01	1-1/2"	1.25	2.17	4.34	3.25	7.75	.94	1.50	1.50	.60	1.28	.625	.377	-	4.20
76-108-01	2"	1.50	2.69	5.43	3.24	7.75	.94	1.50	1.46	.60	1.50	.625	.377	-	6.10
76-109-01	2-1/2"	2.50	3.38	6.75	4.03	7.75	1.38	3.37	1.71	.60	2.00	.625	.377	-	15.60
76-100-01	3"	2.50	3.38	6.75	4.03	7.75	1.38	3.37	1.71	.60	2.00	.625	.377	-	16.50

**For Pressure/Temperature Ratings,
 Refer to Page M-12, Graph No. 14
 (1/4" to 1")
 Refer to Page M-11, Graph No. 12
 (1-1/4" to 2")
 Refer to Page M-10, Graph No. 8
 (2-1/2" to 3")**