

Apollo® 72-100 Series

Carbon Steel High Pressure Ball Valve

Threaded, 3000 psig WOG, Cold Non-Shock Body rating. (See referenced P/T chart)
150 psig Saturated Steam.

Vacuum Service to 29 inches Hg.

Federal Specification: WW-V-35C, Type: II, Composition: CS, Style: 3.

MSS SP-110; Ball Valves Threaded, Socket-Welding, Solder Joint, Grooved and Flared Ends.

FEATURES

- Barstock design
- RPTFE seats and stuffing box ring
- Fire safe design when ordered with graphite packing
- Nitride corrosion protection
- Adjustable packing gland
- Full port, except 2"
- Blow-out-proof stem design
- Heavy duty lever

STANDARD MATERIAL LIST

1. Lever and grip	Steel, zinc plated w/vinyl	7. Gland nut	A108-CS
2. Stem	A108-CS chrome plated	8. Stem packing	RPTFE
3. Stem bearing	RPTFE	9. Lever nut	Steel, zinc plated
4. Retainer seal	RPTFE	10. Body	A108-CS
5. Seat (2)	RPTFE	11. Retainer	A108-CS
6. Ball	A108-CS chrome plated	12. Seat holder	A108-CS

VARIATIONS AVAILABLE:

72-140 Series (316 SS Ball & Stem)

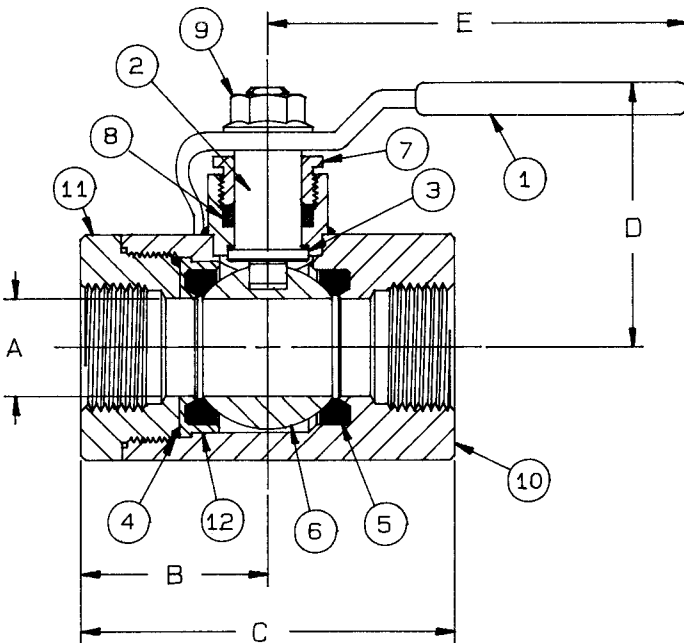

OPTIONS AVAILABLE:

(SUFFIX)	OPTION	SIZES
-02-	Stem Grounded	1/2" to 2"
-03-	1-1/4" CS Stem Extension	1" to 1-1/2"
-04-	2-1/4" CS Stem Extension	1" to 1-1/2"
-07-	Steel Tee Handle	1/2" to 1-1/2"
-08-	90° Reversed Stem	1/2" to 2"
-10-	SS Lever & Nut	1/2" to 1-1/2"
-14-	Side Vented Ball (Uni-Directional)	1/2" to 2"
-15-	Wheel Handle, Steel	1/2" to 1"
-19-	Lock Plate	1/2" to 2"
-21-	UHMWPE Trim (Non-PTFE)	1/2" to 2"
-24-	Graphite Packing	1/2" to 2"
-45-	Less Lever & Nut	1/2" to 2"
-56-	Multifill Seats & Packing	1/2" to 2"
-60-	Static Grounded Ball & Stem	1/2" to 2"
-64-	250# Steam Trim	1/2" to 2"
-77-	Live Loaded 87A/88A Series (Gear & Actuated)	1/2" to 2"
-78-	Delrin Seats, Graphite Packing	1/2" to 2"
-79-	Nylon Seats, Graphite Packing	1/2" to 2"

CARBON STEEL HIGH PRESSURE BALL VALVE

NUMBER	SIZE	A	B	C	D	E	Wt.
72-103-01	1/2"	.62	1.46	2.87	2.50	5.62	1.98
72-104-01	3/4"	.81	1.87	3.80	2.62	5.62	3.09
72-105-01	1"	1.00	2.12	4.15	3.12	6.62	4.87
72-106-01	1-1/4"	1.25	2.32	4.65	3.43	8.00	7.67
72-107-01	1-1/2"	1.50	2.64	5.23	3.56	8.00	10.50
72-108-01	2"	1.75	3.00	5.84	4.18	9.00	15.26

**For Pressure/Temperature Ratings,
Refer to Page M-14, Graph No. 15**