

Table of Contents



OVERVIEW – Inductive Proximity Sensors

Introduction	4
Operation	5



CYLINDRICAL Inductive Proximity Sensors

Introduction/Operation	8
Selection Guide, DC styles	12
Selection Guide, AC styles	14
Product Specifications.....	16



LIMIT STYLE Inductive Proximity Sensors

Introduction/Operation	68
Selection Guide.....	71
Product Specifications.....	72



BLOCK STYLE Inductive Proximity Sensors

Introduction/Operation	80
Selection Guide.....	82
Product Specifications.....	84



RING STYLE Inductive Proximity Sensors

Introduction/Operation	98
Selection Guide.....	100
Product Specifications.....	102

OTHER INFORMATION

APPENDIX:	
IP Codes	132
NEMA requirements	133
Cross Reference	134
Glossary.....	135
Conversion Charts	137
INDEX	138
TERMS & CONDITIONS	141
WARRANTY	143



ACCESSORIES for Inductive Proximity Sensors

Introduction	113
Mounting Brackets	114
Cable Assemblies.....	116
Switching Units.....	122
Motion Detectors.....	128

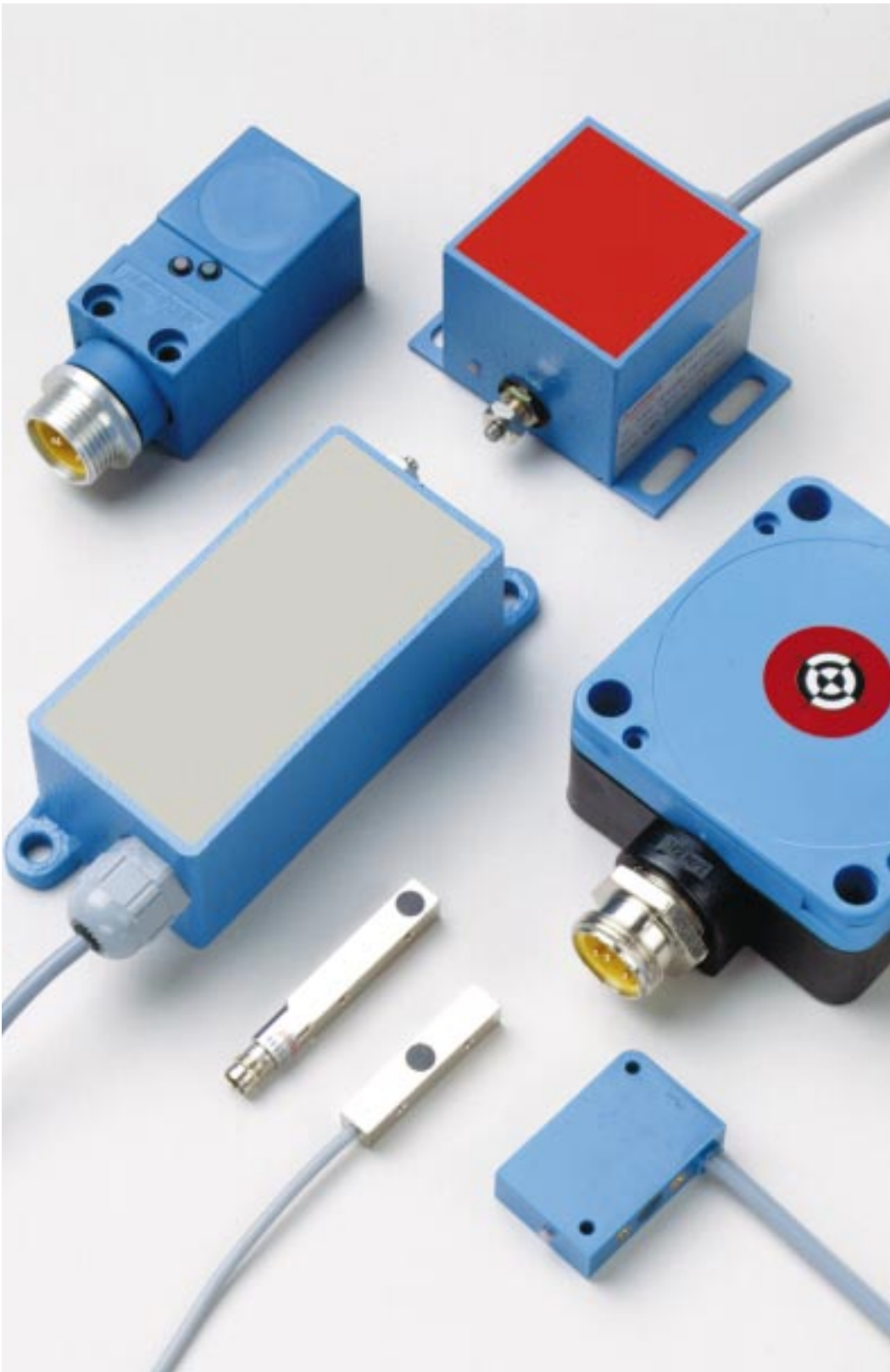

Block Sensors

BLOCK INDUCTIVE PROXIMITY SENSORS

The Altech Inductive Proximity Block Sensor family has a wide selection of housings, with both fixed and adjustable sensing range. Units are available in DC, AC and AC/DC operating voltages.

OUTPUTS NORMALLY OPEN (NO) OR NORMALLY CLOSED (NC)

AC – NO, NC. DC – NO, NC

FLUSH MOUNT VS. NON-FLUSH MOUNT

Block Sensors that are flush mount and have electromagnetic fields directly in front of the sensing head may be mounted directly into metal without causing a false output. The sensing head must be clear of any non-target metal.

Block sensors that are Non-Flush mount have electromagnetic fields with a wide sensing angle. Therefore care must be taken to ensure that no non-target metal comes in contact with the sensing head.

See **Figure 11** for mounting details.

OUTPUT CONNECTIONS

Block sensors are available in 2 meter fixed PVC output cables, quick disconnect connector, or 1/2" 14NPT hole opening for wiring to a terminal block. Please see selection guide on pages 82-83 and the product specification for more information.

HOUSING MATERIAL

The following housing materials are used for housings in the Block Sensor family:

- Aluminum
- PBTP (GV-30)
- Trogamid T
- Aluminum/Trogamid T
- Nickel Plated Brass

Sensing Distances – AC, DC, Block Sensors

Type	Voltage	Flush*	Partially Flush*	Non-Flush*
Mini Block	DC	1.5		
Standard	DC, AC	2		70
Weld Immune	DC, AC		13	2 - 15
Analog	DC			15 - 40

*All Sensing Distances in mm.

Operating Voltages – AC, DC Block Style

AC	20 - 250	90 - 250
DC	10 - 30	18 - 30

Operating Current – AC, DC Block Style

AC	180 mA	500 mA	
DC	5 mA	200 mA	400 mA

Sensor Wiring Systems – AC, DC Block Style

AC	2-Wire	
DC	3-Wire	4-Wire

Fig. 11

BLOCK SENSOR INSTALLATION

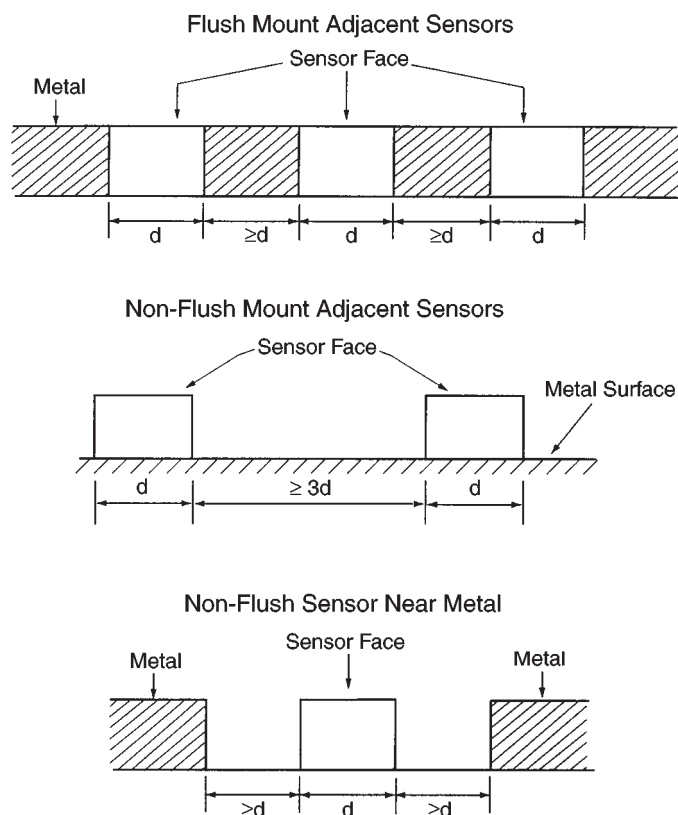

DC BLOCK SENSORS – SELECTION GUIDE

Series	Size (mm)	Sensing Distance (mm)										Mounting			Function				
		1.5	2.0	4.0	6.0	13	15	40	50	70	Adjustable	PF	FL	NF	NPN	PNP	NO	NC	
Mini Housing 10-30V, 200 mA • LED on Connector Styles • Sensing Head at end or center	8 x 8 x 40	•													•		•	•	•
	Standard Series 10-30V, 200/400 mA • Plastic and Metal Housing • Large Sensing Distances • Adjustable Sensing for some models	53 x 22 x 9.5				•										•		•	•
	50 x 50 x 47										•				•		•	•	
	80 x 80 x 40										•	•			•	•	•	•	
	100 x 50 x 40												•	•		•	•	•	
	40 x 12 x 26		•	•											•	•	•	•	
Weld Immune 10-30V, 200 mA • Protection from electro-magnetic interference • 2 LED's	34 x 34 x 80														•		•	•	
	Analog Sensors 10-30V, 5 mA • Output distance proportional to target distance • Excellent linearity ±3% • Determine target position information	80 x 80 x 40														•			

AC BLOCK SENSORS – SELECTION GUIDE

Series	Size (mm)	Sensing Distance (mm)						Mounting			Function		Connection		
		2.0	4.0	13.0	20	40	50	PF	FL	NF	NO	NC	Cable	62	Terminal Block
Standard Series 20-250V AC/ 90-250V • Metal and Plastic Housing • Large Sensing Distance	40 x 26 x 12	•									•	•	•		
	34 x 34 x 80			•							•	•	•		
	50 x 50 x 41				•						•	•	•	•	
	70 x 66 x 60					•					•	•	•		
	80 x 80 x 40						•				•	•	•		•
Weld Immune 20V-250V, 500 mA • Protection from electro-magnetic interference	34 x 34 x 80			•							•	•	•		

	Connection				No. of Wires	Housing Material	No. of LED's	Page
	Cable	Quick Disconnect		Terminal Block				
		59	64					
	•		•		3	Brass, Nickel Plated	1	84
	•				3	Tragamid T	1	88
	•	•			3	Aluminum	1	88
				•	3	PBTP	2	91
	•	•			3	Aluminum	1	90
	•		•	•	3	Trogamid T	1	86
	•				3	PBTP	2	93
				•	3	PBTP	0	92





	No. of Wires*	Housing Construction	No. of LED's	Page
	2	Tragamid T	1	94
	2	PBTP	2	94
	2	Aluminum	2	95
	2	Aluminum	1	95
	2	PBTP	2	95
	2	PBTP	2	96

* A third wire is used for ground on metal sensors

DC - 3 WIRE – MINI BLOCK HOUSING
Brass, Nickel Plated (BN),
Block, 10-30V, 200mA
active surface at front or
centrally located

- Connector styles have **LED for output energized**
- Carries **CE** mark

- IEC (529) IP67 (NEMA 1, 3, 4, 6, 12, 13) Protection
- Short Circuit Protection for PNP types
- Overload Protection
- Reverse Polarity Protection
- Wire Break Resistance
- Temperature Range: -25 to 70°C (-13 to 158°F)

Sensing Distance	Flush Mount Active Surface in Front		Flush Mount Active Surface Centered	
	1.5mm (.059 in.)		1.5mm (.059)	
Cable or Connector Style Cat. No.	Cable	64	Cable	64
PNP Normally Open 	9861-1000	9861-1064	9861-1100	9861-1164
	Normally Closed 			
NPN Normally Open 				
	Normally Closed 			
Ripple Voltage	≤10%		≤10%	
Voltage Range	10V - 30V		10V - 30V	
Supply Current	≤9 mA		≤9 mA	
Max. Load Current	200 mA		200 mA	
Voltage Drop Across Sensor	≤1V		≤1V	
Max. Leakage Current	≤10 μA		≤10 μA	
Switching Frequency	2000 Hz		2000 Hz	
Hysteresis	≤15%		≤15%	
Temperature Drift	≤10%		≤10%	
Repeatability	.15mm (.006 in.)		.15mm (.006 in.)	

Note: Sensor dimensions in mm.

Fixed Cable

PVC 2m (6ft. 6in.). For 5m (16 ft. 5 in.) cable length, change the last two digits of the part number to 02. For other cable lengths and/or PUR cable, please consult Altech.

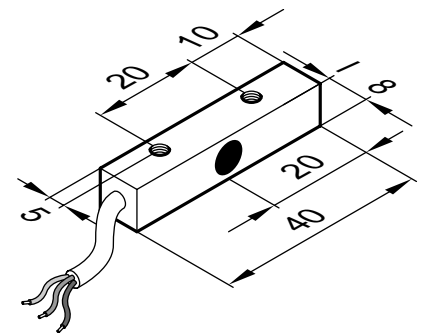
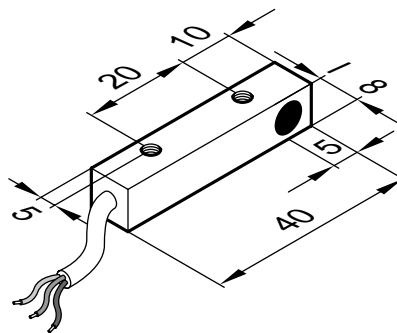

64 Style Connector

3-pin, Pico style, 8mm (.31 in.).

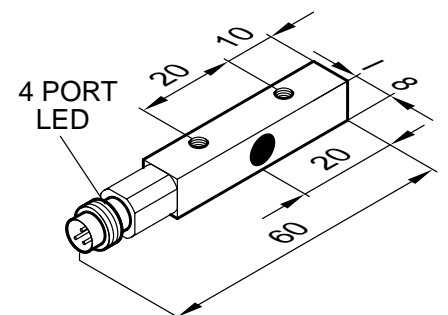
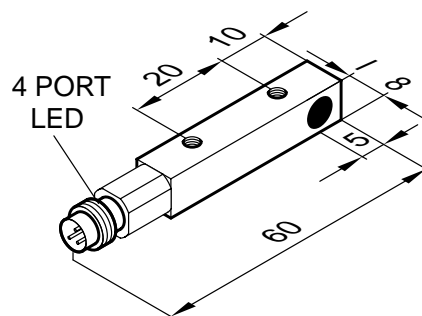

Metric/in. Conversion Table

1.0 mm = .04 in.	20.0 mm = .78 in.
5.0 mm = .19 in.	40.0 mm = 1.57 in.
8.0 mm = .31 in.	60.0 mm = 2.36 in.
10.0 mm = .39 in.	

This table converts millimeters to inches in reference to the illustrations included on these pages

Accessories

2 meter (6 ft. 6 in.) DC Cable Assemblies for Quick Disconnect Sensors

64 Connector	8000-5220	Straight
64 Connector	8000-5230	PVC, Right Angle, 2 LED, PNP
64 Connector	8000-5240	PVC, Right Angle, 2 LED, NPN

Change last digit of connector number to 5 for 5 meter cable

Refer to pages 116-121 for more cable information

Wiring Diagrams

Note: Wire colors are applicable on cable purchased from Altech



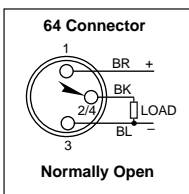
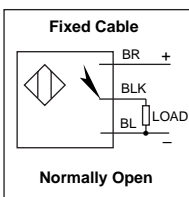

PNP



DC - 3 WIRE
PLASTIC BLOCK HOUSING
10-30V, 400mA
LED for Output Energized

- **Block Sensors feature large sensing distances**
- **Carries $\text{C}\epsilon$ mark**

- IEC(529) IP67 (NEMA 1, 3, 4, 6, 12, 13) Protection
- Short Circuit Protection
- Overload Protection
- Reverse Polarity Protection
- Wire Break Resistance
- Temperature Range: -25 to 70°C (-13 to 158°F)

40 x 26 x 12mm Block Flush Mount			40 x 26 x 12mm Block Non-Flush Mount	
Sensing Distance 2mm (.08 in.)			4mm (.16 in.)	
Cable or Connector Style Cat. No.	Cable	64	Cable	64
PNP	Normally Open 	9863-0400	9863-0464	9863-2700
	Normally Closed 			9863-2764
NPN	Normally Open 	9863-2100	9863-2164	9863-2900
	Normally Closed 			9863-2964
Ripple Voltage	≤10%		≤10%	
Voltage Range	10v - 30V		10v - 30V	
Supply Current	≤18mA		≤18mA	
Maximum Load Current	400 mA (n.o.) 200 mA (n.c.)		400 mA (n.o.) 200 mA (n.c.)	
Voltage Drop Across Sensor	≤2.2V		≤2.2V	
Maximum Leakage Current	≤10μA		≤10μA	
Switching Frequency	800Hz		800Hz	
Hysteresis	≤15%		≤15%	
Temperature Drift	≤10%		≤10%	
Repeatability	.20mm (.008 in.)		.20mm (.008 in.)	
Housing Material	Trogamid T		Trogamid T	

Note: Sensor dimensions in m.

Fixed Cable

PVC 2m (6ft. 6in.). For 5m (16 ft. 5 in.) cable length, change the last two digits of the part number to 02. For other cable lengths and/or PUR cable, please consult Altech.

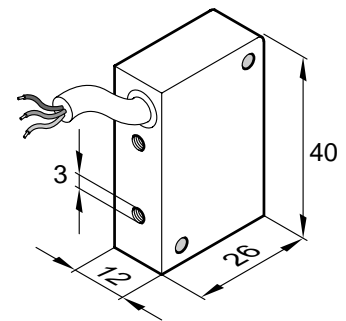
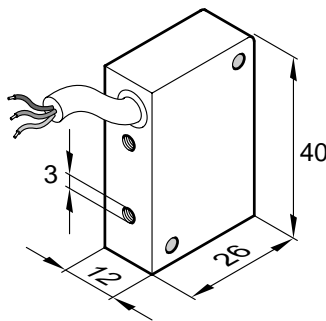

64 Style Connector

3-pin, Pico style, 8mm (.310 in.).

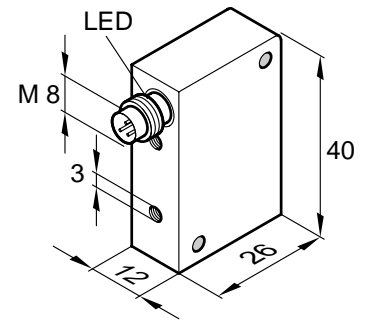
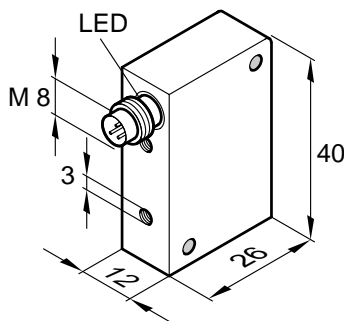

Metric/in. Conversion Table

3.0 mm = .11 in.	26.0 mm = 1.02 in.
8.0 mm = .31 in.	40.0 mm = 1.57 in.
12.0 mm = .47 in.	

This table converts millimeters to inches in reference to the illustrations included on these pages

Accessories

2 meter (6 ft. 6 in.) DC Cable Assemblies for Quick Disconnect Sensors

- 64 Connector 8000-5220 Straight
- 64 Connector 8000-5230 PVC, Right Angle, 2LED, PNP
- 64 Connector 8000-5240 PVC, Right Angle, 2LED, NPN

Change last digit of connector number to 5 for 5 meter cable

Refer to pages 116-121 for more cable information

Wiring Diagrams

Note: Wire colors are applicable to cable purchased from Altech

PNP

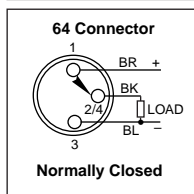
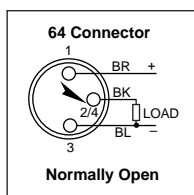
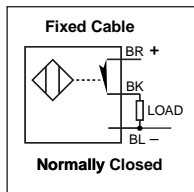
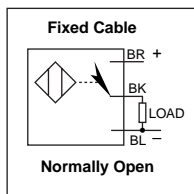

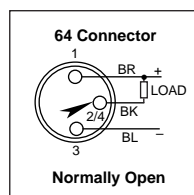
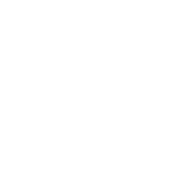
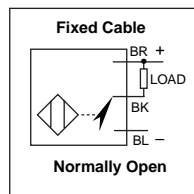

NPN



DC - 3 WIRE – METAL & PLASTIC BLOCK HOUSING
10-30V, 400mA
LED for Output Energized

- **Block Sensors feature large sensing distances**
- **Some models feature adjustable sensing distance**
- **Carries C mark**

- IEC(529) IP67 (NEMA 1, 3, 4, 6, 12, 13) Protection
- Short Circuit Protection
- Overload Protection
- Reverse Polarity Protection
- Wire Break Resistance
- Temperature Range: -25 to 70°C (-13 to 158°F)

		53 x 22 x 9.5mm Block Flush Mount		50 x 50 x 47mm Block Flush Mount					
Sensing Distance		6mm (.24 in.)		Adjustable to 40mm (1.57 in.)					
Cable or Connector Style Cat. No.		Cable		Cable	59	65			
PNP	Normally Open	9864-0200		9807-0900	9807-0959	9807-0965			
	Normally Closed								
NPN	Normally Open	9807-0100							
	Normally Closed								
Ripple Voltage		≤10%					≤10%		
Voltage Range		10v - 30V					10v - 30V		
Supply Current		≤18mA		≤18mA					
Maximum Load Current		400 mA		400 mA					
Voltage Drop Across Sensor		≤2.4V		≤2.4V					
Maximum Leakage Current		≤10μ		≤10μ					
Switching Frequency		100Hz		300Hz					
Hysteresis		≤15%		≤15%					
Temperature Drift		≤10%		≤10%					
Repeatability		.3mm (.012 in.)		2mm (.08 in.)					
Housing Material		Trogamid T		Aluminum					

Note: Sensor dimensions in m

Fixed Cable

PVC 2m (6ft. 6in.). For 5m (16 ft. 5 in.) cable length, change the last two digits of the part number to 02. For other cable lengths and/or PUR cable, please consult Altech.

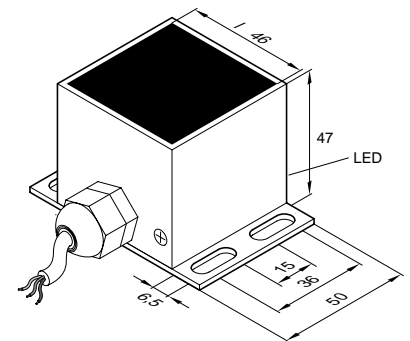
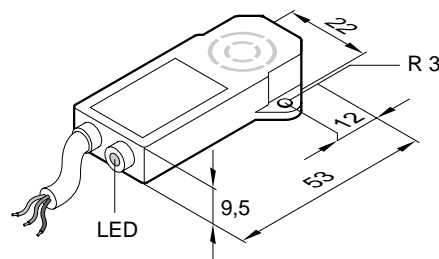

59 Style Connector

4-pin, Metal, 19mm (.75 in.) device.

*** Also available in a 65 Style Connector**

4-pin Micro style, 12mm (.47 in.). Consult Altech.

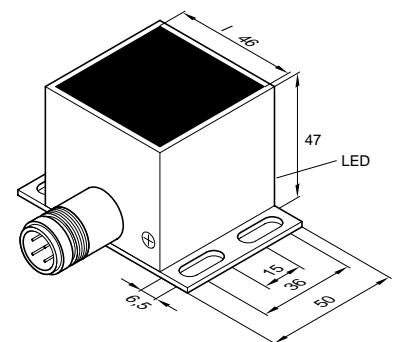

Metric/in. Conversion Table

3.0 mm = .11 in.	36.0 mm = 1.41 in.
6.5 mm = .25 in.	46.0 mm = 1.81 in.
9.5 mm = .37 in.	47.0 mm = 1.85 in.
12.0 mm = .47 in.	50.0 mm = 1.96 in.
15.0 mm = .59 in.	53.0 mm = 2.08 in.
22.0 mm = .86 in.	

This table converts millimeters to inches in reference to the illustrations included on these pages

Accessories

2 meter (6 ft. 6 in.) DC Cable Assemblies for Quick Disconnect Sensors

59 Connector 9512-0200 PVC, Straight

Change last digit of connector number to 2 for 5 meter cable

65 Connector 8000-5110 PVC, Straight

65 Connector 8000-5120 PVC, Right Angle

65 Connector 8000-5150 PVC, Right Angle, 2LED, NPN

65 Connector 8000-5160 PVC, Right Angle, 2LED, PNP

Change last digit of connector number to 5 for 5 meter cable

Refer to pages 116-121 for more cable information

Mounting Brackets – see Pages 114-115

Wiring Diagrams

Note: Wire colors are applicable to cable purchased from Altech

PNP

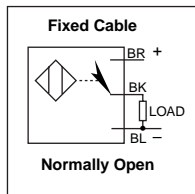

NPN

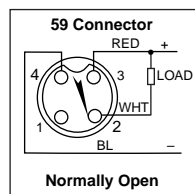
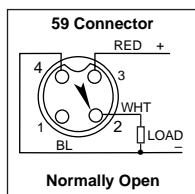
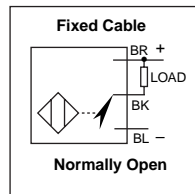



DC - 3 WIRE METAL BLOCK HOUSING 10-30V, 400mA

Selection of operating frequency allows units to be mounted adjacently without interference

- **Block Sensors feature large sensing distances**
- **Some models feature adjustable sensing distance**
- **LED for Output Energized**
- **Carries CE mark**

100 x 50 x 40mm Block Non-Flush Mount Sensing Distance Adjustable to 70mm (2.76 in.)

Cable or Connector Style Cat. No.	Cable	59
PNP Normally Open 	9809-0100 (f1)*	9809-0159 (f1)*
	9809-3400 (f2)*	9809-3459 (f2)*
	9809-3500 (f3)*	9809-3559 (f3)*
NPN Normally Open 	9809-0300 (f1)*	9809-0359 (f1)*
	9809-0400 (f2)*	9809-0459 (f2)*
	9809-0500 (f3)*	9809-0559 (f3)*
Ripple Voltage	≤10%	≤10%
Voltage Range	10V - 30V	10V - 30V
Supply Current	≤12 mA	≤12 mA
Maximum Load Current	400 mA	400 mA
Voltage Drop Across Sensor	≤2.4V	≤2.4V
Maximum Leakage Current	≤10 μA	≤10 μA
Switching Frequency	300Hz	300Hz
Hysteresis	≤15%	≤15%
Temperature Drift	≤10%	≤10%
Repeatability	7mm (.28 in.)	7mm (.028 in.)
Housing Material	Aluminum	Aluminum
LED	One LED	One LED

Note: Sensor dimensions in mm.

Fixed Cable

PVC 2m (6ft. 6in.). For 5m (16 ft. 5 in.) cable length, change the last two digits of the part number to 02. For other cable lengths and/or PUR cable, please consult Altech.

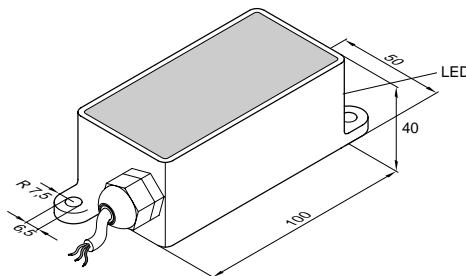

59 Style Connector

4-pin, Metal, 19mm (.75 in.) device

* Also available in a 65 Style Connector
4-pin Micro style, 12mm (.47 in.).
Consult Altech.

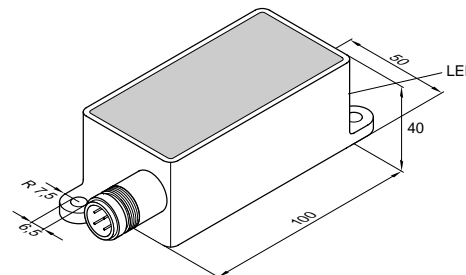

- IEC(529) IP67 (NEMA 1, 3, 4, 6, 12, 13) Protection
- Short Circuit Protection
- Overload Protection
- Reverse Polarity Protection
- Wire Break Resistance
- Temperature Range: -25 to 70°C (-13 to 158°F)

* For operation where units will be located adjacently, models with different operating frequencies must be selected

Metric/in. Conversion Table

6.5 mm = .25 in.	50 mm = 1.96 in.
7.5 mm = .29 in.	100 mm = 3.93 in.
40mm = 1.57 in.	

This table converts millimeters to inches in reference to the illustrations included on these pages

Accessories

2 meter (6 ft. 6 in.) DC Cable Assemblies for Quick Disconnect Sensors

59 Connector 9512-0200 PVC Straight

Change last digit of connector number to 2 for 5 meter cable

Refer to pages 116-121 for more cable information

Wiring Diagrams

Note: Wire colors are applicable to cable purchased from Altech

PNP

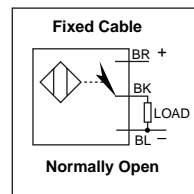

NPN

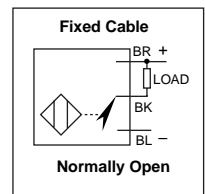

59 Connector

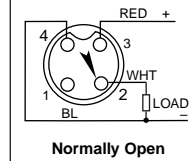

59 Connector

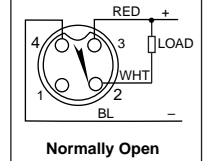

**DC - 3 WIRE
PLASTIC BLOCK HOUSING
10-30V, 200mA
2 LEDs for Operating Voltage
and Output Energized**

- **Block Sensors feature large sensing distances**
- **Complementary Outputs**
- **Carries C mark**

- IEC(529) IP67 (NEMA 1, 3, 4, 6, 12, 13) Protection
- Short Circuit Protection
- Overload Protection
- Reverse Polarity Protection
- Wire Break Resistance
- Temperature Range: -25 to 70°C (-13 to 158°F)

80 x 80 x 40mm Block		
	Flush Mount	Non-Flush Mount
Sensing Distance	40mm (1.57 in.)	50mm (1.97 in.)
Cable or Connector Style Cat. No.	Screw Terminals	Screw Terminals
PNP (Complementary NO/NC)	9865-1133	9865-1033
NPN (Complementary NO/NC)		
Ripple Voltage	≤10%	≤10%
Voltage Range	10V - 30V	10V - 30V
Supply Current	≤22 mA	≤22 mA
Maximum Load Current	200 mA	200 mA
Voltage Drop Across Sensor	≤2.4V	≤2.4V
Maximum Leakage Current	≤10 μA	≤10 μA
Switching Frequency	100Hz	300Hz
Hysteresis	≤10%	≤15%
Temperature Drift	≤10%	≤10%
Repeatability	2mm (.08 in.)	2.5mm (.10 in.)
Housing Material	PBTP	PBTP
LED	Two LEDs	Two LEDs

Metric/in. Conversion Table

11 mm	=	.43 in.
40 mm	=	1.57 in.
80 mm	=	3.15 in.

This table converts millimeters to inches in reference to the illustrations included on these pages

Note: Sensor dimensions in mm.

Wiring Diagrams

Note: Wire colors are applicable to cable purchased from Altech

Screw Terminals
Screw terminals are located internally in housing for wire connections.

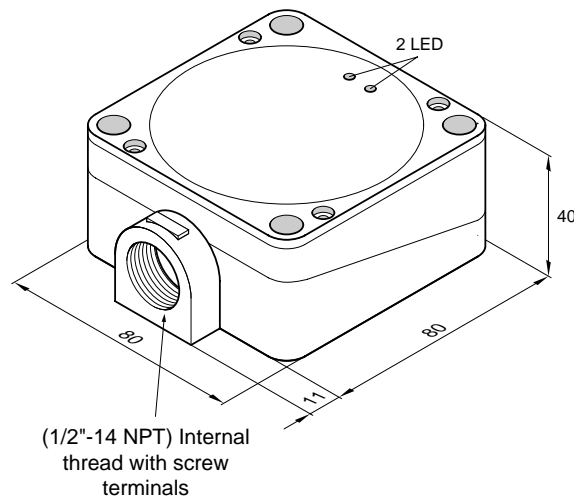

PNP

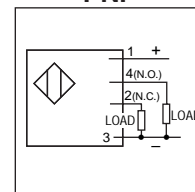

**DC ANALOG SENSORS
BLOCK SERIES**
Plastic (PBTP) Housing
18 - 30V DC
Analog Output 1V - 9V Analog

- *Output voltage proportional to target distance*
- *Ideal for determining position information*
- *Excellent linearity $\pm 3\%$*
- *Carries $\text{C}\epsilon$ mark*

- IEC(529) IP67 (NEMA 1, 3, 4, 6, 12, 13) Protection
- Short Circuit Protection
- Overload Protection
- Temperature Range: -25 to 70°C (-13 to 158°F)

80 x 80 x 40mm Block Non-Flush Mount

Sensing Distance 15mm (.59 in.) to 40mm (1.57 in.)

Cable or Connector Style Cat. No. Screw Terminals

9814-2133

Voltage Range	18V - 30V
Supply Current	≤ 10 mA
Maximum Load Current	5 mA
Maximum Switching Frequency	20Hz
Temperature Drift	$\leq 0.3V$
Repeatability	$\leq 1\%$
Output Voltage Range	1-9V DC
Housing Material	PBTP

Additional Information

The Analog output voltage can be digitized by means of the 8100-2100 Switching Unit and the Modules 8100-2400/-2500

Metric/in. Conversion Table

11.0 mm	=	.43 in.
40.0 mm	=	1.57 in.
80.0 mm	=	3.15 in.

This table converts millimeters to inches in reference to the illustrations included on these pages

Note: Sensor dimensions in mm.

Screw Terminals

Screw terminals are located internally for wire connections.

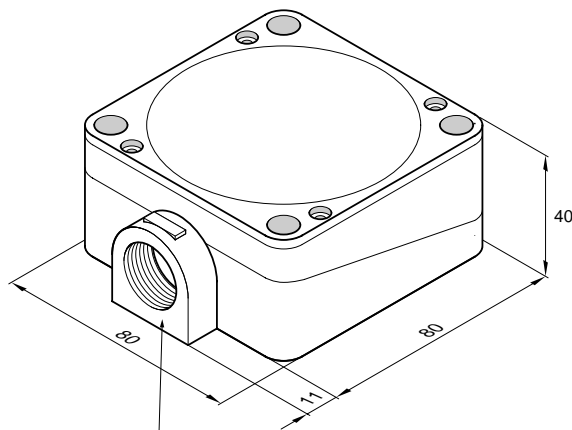

(1/2"-14 NPT)
Internal Thread with
Screw Terminals

Wiring Diagrams

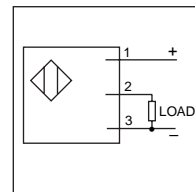

**DC - 3 WIRE WELD IMMUNE
BLOCK, Plastic (PBTP)
10-30V, 200mA
2 LEDs for Operating
Voltage and Output Energized**

- *Circuitry that protects for electromagnetic interference*
- *Carries CE mark*

- IEC(529) IP67 (NEMA 1, 3, 4, 6, 12, 13) Protection
- Short Circuit Protection
- Overload Protection
- Reverse Polarity Protection
- Wire Break Resistance
- Temperature Range: -25 to 70°C (-13 to 158°F)

**34 x 34 x 80mm Block
Partially Flush Mount**

Sensing Distance		13mm (.51 in.)	
Cable or Connector Style	Cat. No.	Cable	Cable
PNP	Normally Open	9863-3800	9863-3900
	Normally Closed		
NPN	Normally Open		
	Normally Closed		
Ripple Voltage		≤10%	≤10%
Voltage Range		10V - 30V	10V - 30V
Supply Current		≤18 mA	≤18 mA
Maximum Load Current		200 mA	200 mA
Voltage Drop Across Sensor		≤2.4V	≤2.4V
Maximum Leakage Current		≤10 μA	≤10 μA
Switching Frequency		15Hz	15Hz
Hysteresis		≤15%	≤15%
Temperature Drift		≤10%	≤10%
Repeatability		1.3mm (.051 in.)	1.3mm (.051 in.)
Housing Material		PBTP (GV 30)	PBTP (GV 30)
Sensing Head Position		Front	Top/Side Rotatable
LED		Two LEDs	Two LEDs

Metric/in. Conversion Table

1.0 mm = .04 in.	66.0 mm = 2.6 in.
5.3 mm = .21 in.	80.0 mm = 3.5 in.
34.0 mm = 1.57 in.	

This table converts millimeters to inches in reference to the illustrations included on these pages

Note: Sensor dimensions in mm.

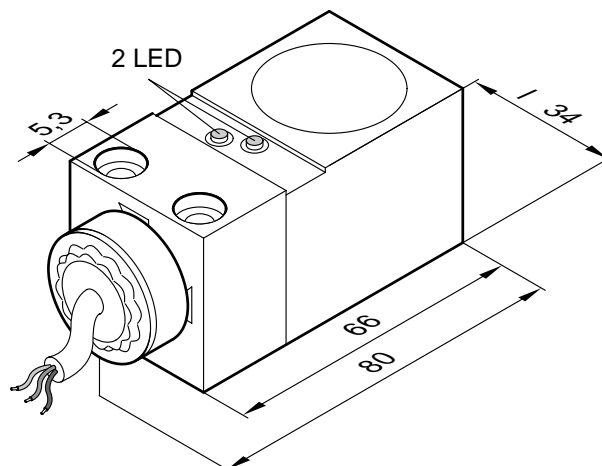

Fixed Cable

PVC 2m (6 ft. 6 in.). Other cable lengths available, please consult Altech.

Wiring Diagrams

Note: Wire colors are applicable to cable purchased from Altech

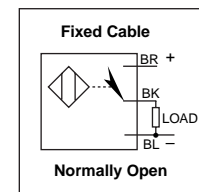

AC - 2 WIRE BLOCK METAL & PLASTIC HOUSING

Models include:
90-250V AC, 180 mA,
20-250V AC, 500mA

- One LED models for Output Energized
- Two LED models for Operating Voltage and Output Energized
- Large sensing distances
- Carries $\text{C}\epsilon$ mark

- IEC (529) IP67 (NEMA 1, 3, 4, 6, 12, 13) Protection
- Temperature Range:
-25 to 50°C (-13 to 122°F)
-25 to 70°C (-13 to 158°F)

Sensing Distance	40 x 26 x 12mm Block Flush Mount		34 x 34 x 80mm Block Partially Flush Mount	
	2mm (.08 in.)		13mm (.51 in.)	
Cable or Connector Style Cat. No.	Cable	Cable	Cable	Cable
Normally Open 	9853-2400	9853-3800	9853-3900	
Normally Closed 	9853-2500	9853-3600	9853-3700	
Voltage Range	90V-250V AC	20V - 250V AC	20V - 250V	
Operating Frequency	50/60Hz	50/60Hz	50/60Hz	
Supply Current	≤5 mA	≤2 mA	≤2 mA	
Max. Load Current	180 mA	500 mA	500 mA	
Voltage Drop Across Sensor	≤12V	≤5V	≤5V	
Max. Leakage Current	≤3mA/230V ≤1.5mA/110V	≤2mA	≤2mA	
Short Term Current (20 ms, 1Hz)	1A	8A	8A	
Switching Frequency	25Hz	15Hz	15Hz	
Hysteresis	≤15%	≤15%	≤15%	
Temperature Drift	≤10%	≤10%	≤10%	
Repeatability	.2mm (.008 in.)	1.3mm (.051 in.)	1.3mm (.051 in.)	
Housing Material	Trogamid T	PBTP (GV 30)	PBTP (GV 30)	
Sensing Head Position	-	Active Surface in Front	Active Surface on Top - Rotatable	

Fixed Cable

PVC 2m (6ft. 6in.). For 5m (16 ft. 5 in.) cable length, change the last two digits of the part number to 02. For other cable lengths and/or PUR cable, please consult Altech.

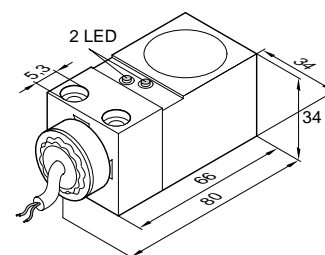
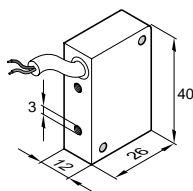

62 Connector

3-Pin Mini Style, 25.4mm (1.0 in.).

Screw Terminals

Screw terminals are located internally in housing for wire connection.

Metric/in. Conversion Table

3.0 mm = 0.1 in.	50.0 mm = 1.96 in.
5.3 mm = 0.2 in.	60.0 mm = 2.36 in.
6.5 mm = .25 in.	64.0 mm = 2.52 in.
12.0 mm = .47 in.	66.0 mm = 2.59 in.
24.0 mm = .94 in.	70.0 mm = 2.75 in.
26.0 mm = 1.02 in.	80.0 mm = 3.15 in.
34.0 mm = 1.33 in.	90.0 mm = 3.54 in.
40.0 mm = 1.57 in.	110.0mm = 4.33 in.
41.0 mm = 1.61 in.	
45.0 mm = 1.77 in.	

This table converts millimeters to inches in reference to the illustrations included on these pages

Accessories

2 meter (6 ft. 6 in.) AC Cable Assemblies for Quick Disconnect Sensors

62 Connector 8000-5030 PVC Straight

Change last digit of connector number to 5 for 5 meter cable

Refer to pages 116-121 for more cable information

Mounting Brackets – see Pages 114-115

50 x 50 x 41mm Block Flush Mount

70 x 66 x 60mm Block Flush Mount

80 x 80 x 40mm Block Non-Flush Mount

20mm (.79 in.)

40mm (1.57 in.)

50mm (1.97 in.)

62

Cable

Screw Terminals

9855-0062

9803-3000

9855-1000

9855-1100

20V - 250V

20V - 250V

20V - 250V

50/60Hz

50/60Hz

50/60Hz

≤2 mA

≤2 mA

≤2 mA

500 mA

500 mA

500 mA

≤5V

≤5V

≤5V

≤2 mA

≤2 mA

≤2 mA

8A

8A

8A

15Hz

25Hz

10Hz

≤15%

≤15%

≤15%

≤10%

≤10%

≤10%

2mm (.079 in.)

4mm (.157 in.)

5mm (.197 in.)

Aluminum

Aluminum

PBTP (GV 30)

Note: Sensor dimensions in mm.

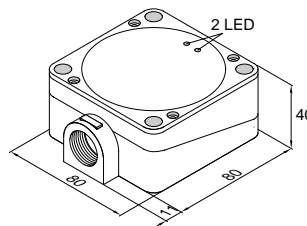
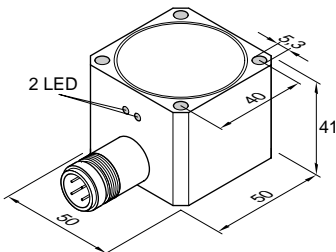
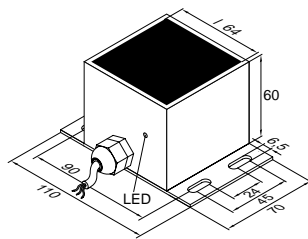

Wiring Diagrams

Note: Wire colors are applicable to cable purchased from Altech

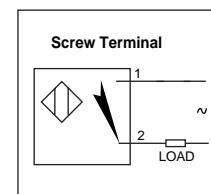
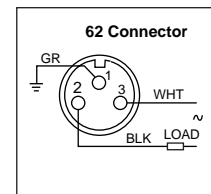
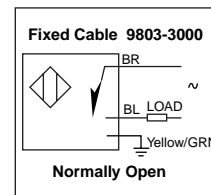
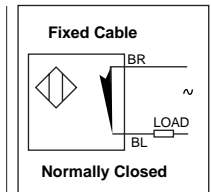
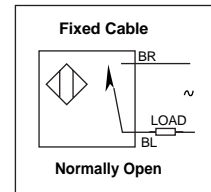



**AC - 2 WIRE WELD IMMUNE
BLOCK, Plastic Housing
20-250V AC, 500mA
2 LEDs for Operating
Voltage and Output Energized**

• **Circuitry that protects for electromagnetic interference**

• **Carries C mark**

- IEC(529) IP67 (NEMA 1, 3, 4, 6, 12, 13) Protection
- Temperature Range: -25 to 70°C (-13 to 158°F)

**34 x 34 x 80mm Block
Partially Flush Mount**

Sensing Distance		13mm (.51 in.)	
Cable or Connector Style	Cat. No.	Cable	Cable
Normally Open		9853-3800	9853-3900
Normally Closed		9853-3600	9853-3700
Voltage Range		20V - 250V AC	20V - 250V AC
Operating Frequency		50/60Hz	50/60Hz
Supply Current		≤2 mA	≤2 mA
Maximum Load Current		500 mA	500 mA
Voltage Drop Across Sensor		≤5V	≤5V
Maximum Leakage Current		≤2 mA	≤2 mA
Short Term Current (20 ms, 1Hz)		8A	8A
Switching Frequency		15Hz	15Hz
Hysteresis		≤15%	≤15%
Temperature Drift		≤10%	≤10%
Repeatability		.65mm (.026 in.)	.65mm (.026 in.)
Housing Material		PBTP (GV 30)	PBTP (GV 30)
Sensing Head Position		Front	Top/Side Rotatable

Note: Sensor dimensions in mm.

Fixed Cable

PVC 2m (6ft. 6in.). For 5m (16 ft. 5 in.) cable length, change the last two digits of the part number to 02. For other cable lengths and/or PUR cable, please consult Altech.

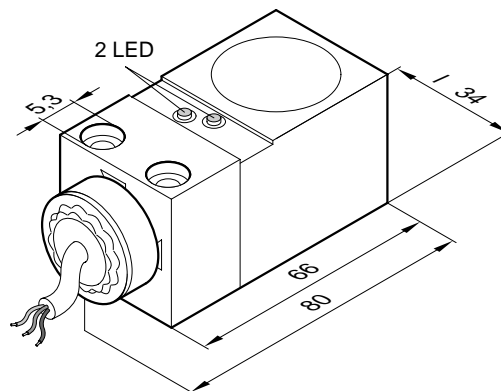

Metric/in. Conversion Table

1.0 mm = .04 in.	66.0 mm = 2.6 in.
5.3 mm = .21 in.	80.0 mm = 3.5 in.
34.0 mm = 1.57 in.	

This table converts millimeters to inches in reference to the illustrations included on these pages

Accessories

Mounting Brackets – see Pages 114-115

Wiring Diagrams

Note: Wire colors are applicable to cable purchased from Altech

